

Optical Memory Storage Devices

Mohammad Al-Fayez, Sulaiman Redha, Othman Al-enzi,
 Suad Al-Saleh, Humoud Alqattan

Abstract — *Optical memory storage devices are introduced in this report as a promising tool in which a laser beam is utilized to save and retrieve data on optical media. The evolution of storage devices in terms of shape, structure and technology has experienced many improvements and adjustments to meet the storage capacity demand, minimize energy consumed and elongate the life time of the device to stand harsh environment such as temperature and accidents. Different design approaches are proposed for optical storage devices such as digital thin-film and difference frequency generation, where each of which has unique structure, operating theory, advantages and limitations.*

Date of Submission: 27-04-2026

Date of acceptance: 06-05-2026

I. INTRODUCTION

The necessity to store information over time is associated with the ultimate demand to continuously develop new tools to save the large volume of data required in different life aspects for future references. As shown in Fig. 1, the evolution process of storing started from painting and ended with digitizing that needs to be improved to meet the vast global growth in data generation, which may reach 35 ZB (35 ZB = 35 x 10¹² GB) in 2020 according to the International Data Corporation (IDC) report, Fig. 2 [1].

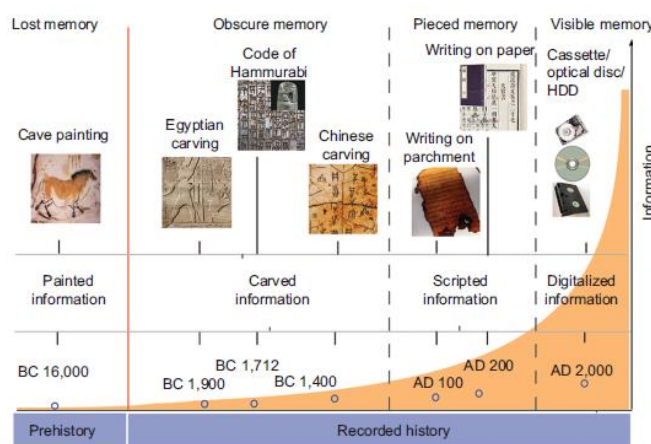

Fig. 1. Evolution process of storing information.

According to a report issued by the International Data Corporation (IDC), the global growth in data generation may reach 35 ZB (35 ZB = 35 x 10¹² GB) in 2020 with the majority of information being saved on hard disc drives (HDD), followed by tapes, other forms of storage devices and optical discs as illustrated in Fig. 2 [1].

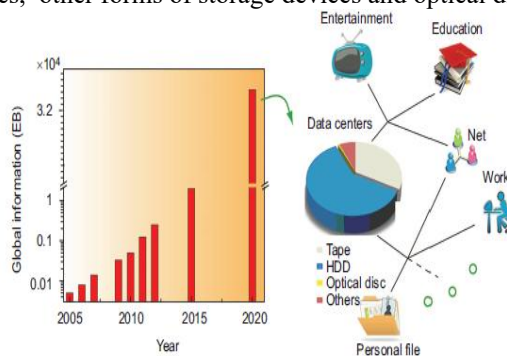

Fig. 2. Annual growth of global information (left) and percentage of various storage tools used for storing data (right).

II. OPTICAL STORAGE DEVICES

A. Evolution

Optical memory storage devices utilize a light or a laser beam to save and retrieve information [2]. The origin of such devices started in 1969 where data were stored on a ring around a disc and it consisted of pits and lands that represent the stored data. Later in 1975 Laservision were developed for video types of data and were commonly used in Japan. However, in 1982, Sony Company produced compact discs (CD) for audio data and different types were developed such as CD-ROM and CD-RW. DVDs which stands for digital versatile discs were released to the market in 1998 and after which new storage technologies were invented such as Blu-Ray discs by Sony Company in 2004. Since then, scientists are trying to increase the storage capacity of DVDs and other optical discs by improving their optical characteristics and performance efficiency [3].

B. Structure And Operating Mechanism

The optical storage compact disc (CD) shown in Fig. 3 has four layers: label, protective layer, reflective layer, and substrate layer. The substrate layer is made of a polycarbonate material and contains pits and lands. Pits are holes with a $0.12\ \mu\text{m}$ depth and lands are free spaces between the pits, Fig. 3 [4].

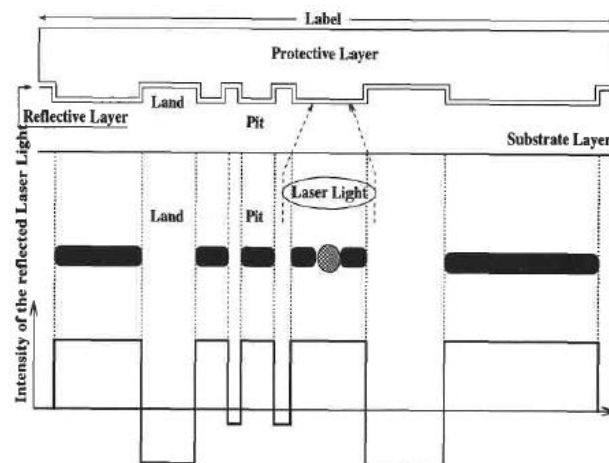

Fig. 3. Optical CD structure.

The operating mechanism of an optical storage device, i.e. a CD, starts when a laser beam of a $780\ \text{nm}$ wavelength scans the rotating CD inside a CD player. The laser beam scans the track, which is a circular shaped structure located at a distance r from the CD center, shown in Fig. 4 from the center outward. Beam is reflected by the disc and then diverted by a prism to be detected by a photocell. Beams reflected due to lands have high intensities compared to the scattered beams by the pits (low intensity). The photocell responds to the reflected beams by producing binary digits 1 and 0 to identify the information state [4].

Data are stored on sectors or small segments on the track, where each segment is occupied by a single block of data of 512 or 1024 bytes [4] and [5].

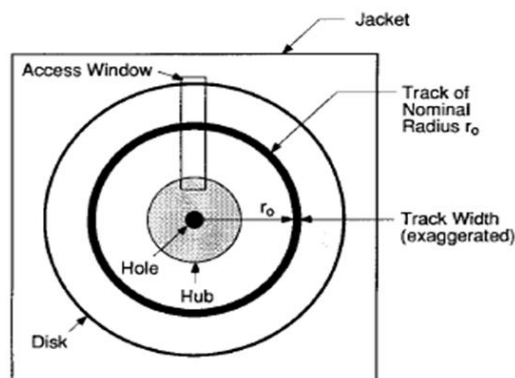

Fig. 4. Optical disc with track location.

C. Performance Parameters

Describing the performance of optical storage devices requires identifying some parameters and terms to understand its operation.

1. Disc Rotation Speed

The track has a linear velocity V that depends on the angular velocity ω of the rotating disc and the radius r of the track according to the equation below

$$V = r \omega. \quad (1)$$

Slow drives have a rotational speed of 1200 rpm and 1800 rpm and high speed drives rotate at 3600 rpm [5].

2. Access Time

Access time τ_a is the average time required to move from one random location on the disc to another and it can be computed using the equation shown below

$$\tau_a = \tau_s + \tau_l. \quad (2)$$

Where τ_s is the seek time and it is defined as the average time required to obtain the target track of interest and the latency time τ_l is the average waiting time on the target track for the required sector [5].

The τ_s ranges from 20 ms – 100 ms for optical drives and it depends on the drive size as longer time is associated with large drives.

3. Organization of Data on disc

As mentioned earlier, data are saved on segments on the track but before saving, error correction coding and modulation coding have to be accomplished to protect data and avoid errors and adjust the data to occupy the track sectors [5].

D. Design Approaches

Different optical memory storage device designs were introduced, each with unique technology as discussed below

1. Difference Frequency Generation (DFG)

In optical storage DFG based device, the memory is composed of 4 DFG units, 8 filters: v_1 and v_2 represent 0 and 1 information states respectively, 3 beam splitters (B.S) and 3 mirrors (M) as shown in Fig. 5 with A being the input and Q and \tilde{Q} being the outputs.

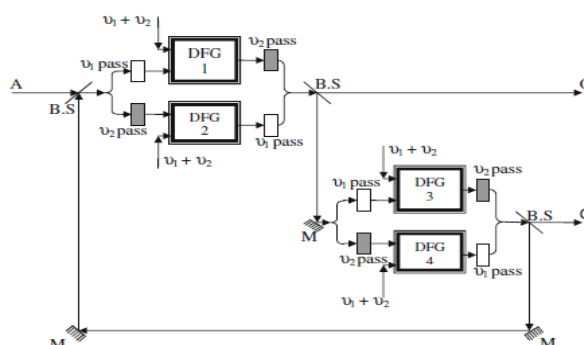

Fig. 5. DFG based memory device schematic-structure.

Coding data occurs when the input A consists of a beam of photons of frequency of v_1 ('0') passes through v_1 filter and DFG unit 1 and produces v_2 photons with frequency of v_2 ('1') as the output Q. At the same time, some of v_2 ('1') photons enter v_2 pass filter and DFG unit 4 where v_2 ('1') frequency photons transfer to v_1 ('0') frequency photon and they become the output \tilde{Q} . The same operation principle is applied when the input signal consists of v_2 ('1') or when it is switched off since it is a continuous cycle.

Clearing the memory can be achieved by switching the input signal off where the output \tilde{Q} becomes the only input and one of the filters is blocked by the other because there is no difference in frequency generation and there is not output Q.

The suggested non-linear materials for the DFG are LiB3O5 (LBO) and β -BaB2O4 (BBO) where the operation bandwidth is in the 370 nm-2600 nm and 200 nm-3500 nm wavelength range respectively. The main issue with this approach is the DFG principle that is considered power consumable and inefficient compared to other technologies. However, the approach can be improved by enhancing the DFG material's properties [6].

2. Digital Thin Film (DTF)

The second design approach presented in this report is the DTF optical memory device shown in Fig. 6.

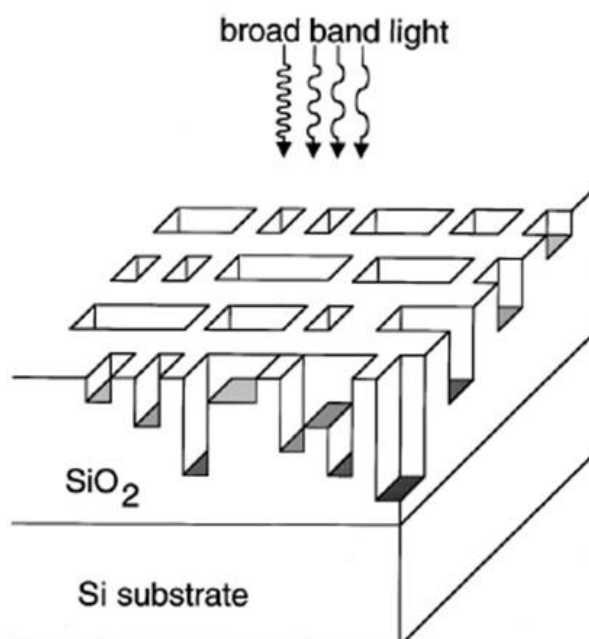

Fig. 6. Structure of DTF based optical device.

This type of optical memory device consists of a silicon substrate with a thin silicon dioxide SiO₂ film of 800 nm thickness. The film is micromilled using Ga⁺ focused ion beam (FIB) to create arrays of different depths and thicknesses. As a broad band light source is directed toward the arrays, it is reflected and can be captured and examined using optical microscope and analog charge-coupled device camera (CCD) and video frame grabber. An optical image is produced with different colors, each corresponds to an array depth and thickness as illustrated in Fig 7 and Fig. 8.

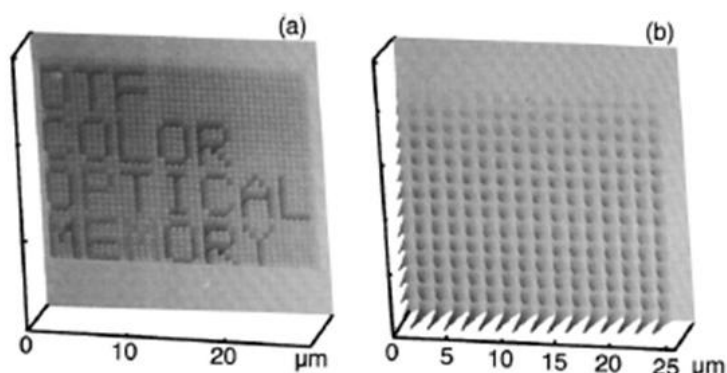

Fig. 7. Atomic force microscopy array image of two different dimensions of DTF structure arrays.



Fig. 8. DTF structure with color reflected light photograph.

The main advantage of this approach is the ability to increase the device density from 5 Gb/ in² to 2 Tb/ in² in the future.

III. OBSTACLES AND IMPROVEMENTS

No one can deny the benefits of optical memory storage devices and their advantages that include, size variation, price reasonability, and transportation flexibility.

Many studies have shown that storage devices are affected by environmental factors such as high temperature, light and humidity in addition to chemical reactions such as corrosion. Such factors would destroy the storage device including the stored information. Table 1 provides a summary for the life expectancy of different storage devices [8].

Enhancing the present storage devices in general and optical ones in particular requires time and effort. Working on the device material properties is one access key to produce a substance that can tolerate different rough physical, environmental and chemical circumstances.

Another perspective that can be considered is the operating principle of the storage device since some technologies overcome others and can be improved with further investigations.

Table 1: life expectancy of some storage devices

Media	Life Expectancy of Data
Magnetic tape	10-50 years
Magnetic hard-disk drives	1-7 years
Flash drives and Solid-state drives	10-12 years
Recordable optical discs	1-25 years
Millennia recordable optical discs	1000 (advertised)

IV. CONCLUSION

Optical memory storage devices have the potential to be a powerful storage tool in the future because of its technology and characteristics. By enhancing the performance parameters such as access time and storage capacity, obstacles can be overcome to obtain high quality, efficient and long lasting storage tools.

REFERENCES

- [1]. Gu, Min, Xiangping Li, and Yaoyu Cao. "Optical storage arrays: a perspective for future big data." *Light: Science & Applications* 3.E177 (2014): 1-11. Print.
- [2]. Meinders, Erwin R., Andrei V. Mijiritskii, Liesbeth Van Pieterse, and Matthias Wuttig. *Optical data storage: phase-change media and recording*. Vol. 4. Dordrecht: Springer, 2006. Print.
- [3]. Burkhart, Sam. "Optical Data Storage: The past, present, and a possible." (2009): 1-11. Web. 20 Dec. 2016.
- [4]. Steinmetz, Ralf, and Klara Nahrstedt. *Multimedia: Computing, Communications, and Applications*. NJ: Prentice-Hall, 1995. Print.
- [5]. Bass, Michael. *Handbook of optics. Fundamentals, techniques, and design*. Vol. 1. London: McGraw-Hill, 1995. Print.
- [6]. Mukherjee, Kousik, Ajit Kumar Meikap, and Dharmadas Kumbhakar. "Frequency encoded all optical single bit memory unit using difference frequency generation alone." *Opt Quant Electron* 43 (2012): 101-07. Web. 20 Dec. 2016.
- [7]. Chi, C. J., and A. J. Steckla. "Digital thin-film color optical memory." *APPLIED PHYSICS LETTERS* 78.2 (2001): 255-57. Web. 20 Dec. 2016.
- [8]. Lunt, Barry M. "How Long Is Long-Term Data Storage?" *How Long Is Long-Term Data Storage?* (2011): 29-33. Web. 20 Dec. 2016.